

A5s

Receiving Card



Product Description

Document Version: V1.1.0

Document Number: NS110100419

Copyright © 2018 Xi'an NovaStar Tech Co., Ltd. All Rights Reserved.

No part of this document may be copied, reproduced, extracted or transmitted in any form or by any means without the prior written consent of Xi'an NovaStar Tech Co., Ltd.

Trademark

 is a trademark of Xi'an NovaStar Tech Co., Ltd.

Statement

You are welcome to use the product of Xi'an NovaStar Tech Co., Ltd. (hereinafter referred to as NovaStar). This document is intended to help you understand and use the product. For accuracy and reliability, NovaStar may make improvements and/or changes to this document at any time and without notice. Any problem in use or any good suggestion, please contact us through ways provided in the document. We will do our utmost to solve the problems and adopt the suggestions after evaluation as soon as possible.

XI'AN NOVASTAR TECH CO., LTD.

Change History

Version	Release Date	Description
V1.1.0	2018-01-25	<ul style="list-style-type: none">• Updated the loading capacity to 320×256 (PWM IC) pixels.• Added the following functions:<ul style="list-style-type: none">- LVDS transmission (customized function)- Image rotating in 90° increments
V1.0.2	2017-07-28	Optimized the document content and structure.
V1.0.1	2017-05-15	Optimized the document content.
V1.0.0	2016-12-15	First release

Contents

1 Safety	1
1.1 Storage and Transport Safety.....	1
1.2 Installation and Use Safety.....	1
2 Overview.....	2
3 Characteristics.....	3
3.1 Improvement in Display Effect.....	3
3.2 Improvement in Maintainability	3
3.3 Improvement in Hardware Reliability	4
3.4 Improvement in Software Reliability	5
4 Hardware Structure.....	6
4.1 Appearance.....	6
4.2 Dimensions	6
4.3 Indicator	7
4.4 Definition of the Data Interface (Top).....	8
4.4.1 32-Group Parallel Data Interface.....	8
4.4.2 64-Group Serial Data Interface.....	11
4.4.3 Reference Design for Expandable Interfaces.....	14
5 Software Structure	16
6 Typical Networking.....	17
7 Specifications.....	18
A Acronyms and Abbreviations.....	19
B Terms	20

1 Safety

This chapter illustrates the safety of the A5s receiving card to ensure products' storage, transport, packing and application safety. Safety description is applicable to all personnel that contact or use the products. Pay attention to following points:

- Read throughout the description.
- Save the whole description.
- Be complied with the whole description.

1.1 Storage and Transport Safety

- Pay attention to dust and water prevention.
- Avoid long-term direct sunlight.
- Do not place the products at the position near fire and heat.
- Do not place the products in an area containing explosive materials.
- Do not place the products in strong electromagnetic environment.
- Place the products at a stable position to prevent damage or personal injury caused by dropping.
- Save the packing box and materials which will come in handy if you ever have to ship your products. For maximum protection, repack your product as it was originally packed at the factory.

1.2 Installation and Use Safety

- Only trained professionals may install the products.
- Do not insert and unplug (power cord plug) when the power is on.
- Ensure the safe grounding of the device.
- Always wear an anti-static wrist band and insulating gloves.
- Do not place the products in an area having more or strong shake.
- Perform dust removing regularly.
- Do not maintain the products without authorization but contact NovaStar as soon as possible.
- Replace spare parts only with the same parts supplied by NovaStar.

2 Overview

A5s is a high-end receiving card developed by NovaStar, featuring small size and large loading capacity with the single card loading capacity up to 320x256 (PWM IC) pixels.

A5s supports pixel level brightness and chroma calibration, which removes color difference effectively and improves display consistency of LED images. In addition, it also supports image rotation in 90° increments, creating richer images and improving visual experiences.

Software and hardware designs of the A5s concern the user deployment as well as operating and maintenance scenarios, enabling easier deployment, more stable operating and more efficient maintenance.

Advanced hardware design:

- Small size and thinner thickness save space for increasingly narrower cabinet space and smaller spacing between lamps.
- Use high-density connector which is resistant to dust and vibration and features high stability and high reliability.
- Assembly network transformer features simple design and improved magnetic compatibility, helping user's products to successfully pass the EMC authentication.

Useful software design:

- Support for LVDS transmission (customized function)
- Support for smart module (customized function)
- Support for auto module calibration
- Support for Mapping function
- Support for pre-stored image setting of the receiving card
- Support for module Flash management
- Support for monitoring of temperature, power supply voltage
- Support for monitoring of Ethernet cable communication status (customized function)
- Support for 5-pin LCD module
- Support for image rotating in 90° increments

3 Characteristics

3.1 Improvement in Display Effect

Characteristics	Description
Supporting pixel level brightness and chroma calibration	Pixel level brightness and chroma calibration on NovaLCT could remove color difference effectively, make the brightness and chroma of the whole screen highly consistent, and improve display effect.
Supporting image rotating in 90° increments (Calibration of the rotated image not supported)	On NovaLCT, the image on the screen can be set to rotate in the multiples of 90° (90°, 180°, 270° and 360°).

3.2 Improvement in Maintainability

Characteristics	Description
Supporting the smart module (Customized function)	The smart module is composed of Flash and MCU. Flash could store calibration coefficients and module information. MCU could communicate with the receiving card to realize monitoring over temperature, voltage and wiring communication status, as well as LED error detection. The smart module could make monitoring unit smaller, requiring no independent monitoring card and saving cabinet space.
Supporting LVDS transmission (Customized function)	The transmission mode of low-voltage differential signaling (LVDS) is used, which reduces the number of data cables that connect the receiving card's HUB board to the module, increases the transmission distance, improves the signal transmission quality, enhances the EMC effect, and better stabilizes the image output.

Characteristics	Description
Supporting module auto calibration	After the module has been replaced, the receiving card can automatically read the new module ID and calibration coefficient which could be saved to calibration system files.
Supporting Mapping function	Enable the Mapping function on NovaLCT, then the target cabinet will display the cabinet number and Ethernet port information, and the user could get the receiving card's location and wiring route.
Supporting stored image setting of the receiving card	On NovaLCT, the specified images could be set as the startup image and images used when there is no network or video source.
Supporting module Flash management	On NovaLCT, the module Flash could be enabled.
Supporting monitoring over temperature, voltage and wiring status	On NovaLCT, temperature, voltage and wiring status of the receiving card could be checked.
Supporting LCD module	Support NovaStar's product 5-pin LCD module which is connected to HUB to display temperature, voltage, single operating time and total operating time of the receiving card.
Support one-click module Flash calibration coefficient.	In the event of network outage, hold down the self-test button to read the module Flash calibration coefficient back to the receiving card.

3.3 Improvement in Hardware Reliability

Characteristics	Description
Supporting dual-card backup	In the high-reliability environment, single HUB board could be populated with two A5s receiving cards. In case that the main receiving card fails, the standby one will serve in a timely manner to ensure normal operation of the display.
Supporting dual-power backup & detection	Two power supplies could be simultaneously connected, and operating status of the power supplies could be detected.
Supporting hot backup	Hot backup is used to improve business and connection reliability: <ul style="list-style-type: none"> • Device redundant backup: The device

	<p>connected to the receiving card improves business reliability through main and standby redundant mechanism. Only the main device is running at a certain time. The standby device begins to work to ensure the normal operation of the display while the main device fails.</p> <ul style="list-style-type: none"> • Ethernet port redundant backup: HUB's Ethernet port improves the reliability for the serial connection of the receiving card through main and standby redundant mechanism. Among the main and standby serial connection lines, if one fails, the other will begin to work to ensure the normal operation of the display.
--	---

3.4 Improvement in Software Reliability

Characteristics	Description
Supporting firmware read back	Information saved in the receiving card could be read back on the NovaLCT.
Supporting dual-backup and restoring of the calibration coefficient	Calibration coefficients could be saved to both the factory area and application area at the same time. Calibration coefficients in the factory area is default as the delivery value, while the calibration coefficient in the application area could be modified or be restored to the factory reset by the user on NovaLCT.
Supporting configuration parameter backup for the receiving card	The user could back up configuration parameters on NovaLCT.

4 Hardware Structure

4.1 Appearance

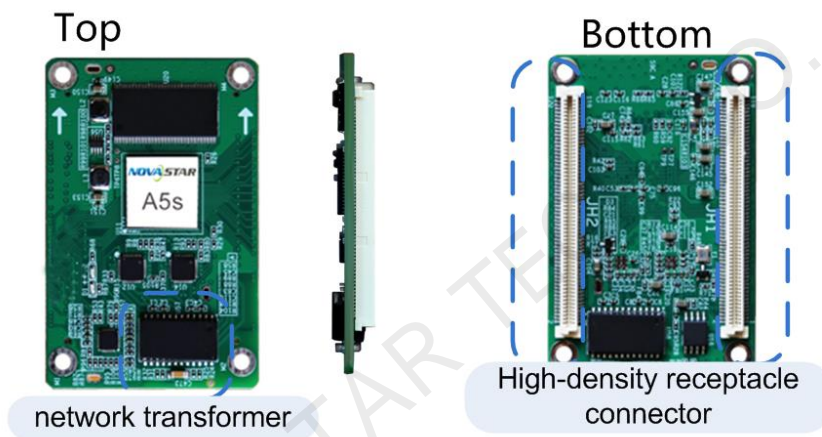

Product images provided in this file are for reference only, and the actual products shall prevail.

Models of the high-density receptacle and plug used by A5s are shown in [Table 4-1](#).

Table 4-1 Model of high-density connector

Type	Brand	Material Code
Receptacle	Amphenol FCI	10140609-121802LF
PLUG	Amphenol FCI	10140607-121802LF

4.2 Dimensions

Board thickness is not greater than 2.0mm, and the total thickness (board thickness + thickness of both front panel and back panel) is not greater than 7.5mm.

Unit of the dimension chart is “mm”. Ground connection is enabled for location hole (GND).

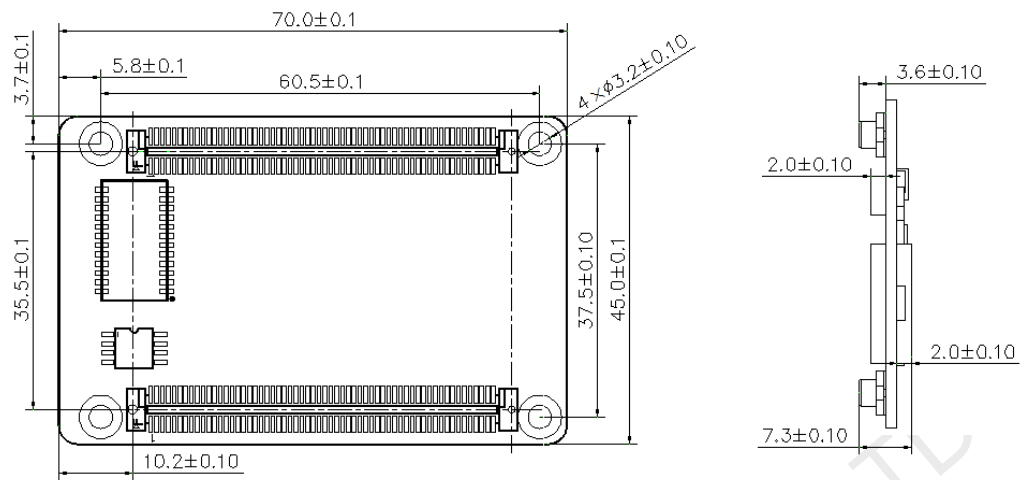

4.3 Indicator

Indicator	Status	Description
Status indicator (green)	Flash every other 1s.	The receiving card works normally, Ethernet cable connection is normal, and video source input is available.
	Flash every other 3s.	The receiving card works normally, while the Ethernet cable connection is abnormal.
	Rapidly flash for 3 times every other 3s.	The receiving card works normally, Ethernet cable connection is normal, while no video source input is available.
	Rapidly flash every other 0.5s.	Program loading fails in normal operating state, coming to the backup operating state.
Status indicator (red)	Remain lit.	It remains lit after the power is on.

4.4 Definition of the Data Interface (Top)

4.4.1 32-Group Parallel Data Interface

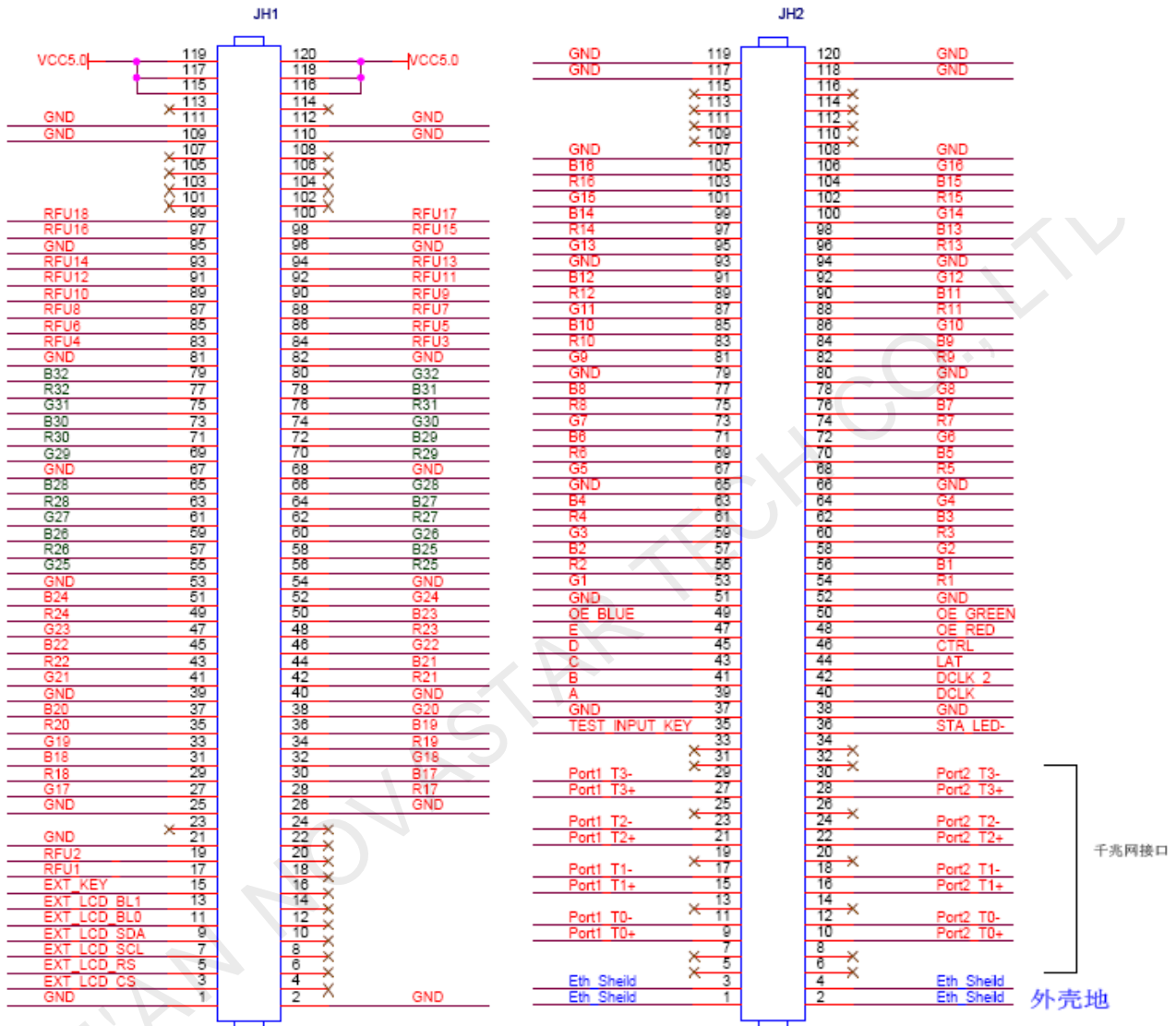

		JH1					
		GND	1	2	GND		
LCD	CS signal of LCD	EXT_LCD_CS	3	4	NC		
	RS signal of LCD	EXT_LCD_RS	5	6	NC		
	Clock signal of LCD	EXT_LCD_SCL	7	8	NC		
	Data signal of LCD	EXT_LCD_SDA	9	10	NC		
	Backlight signal 1 of LCD	EXT_LCD_BL0	11	12	NC		
	Backlight signal 2 of LCD	EXT_LCD_BL1	13	14	NC		
	LCD control button	EXT_KEY	15	16	NC		
Note 5	/	RFU1	17	18	NC		
	/	RFU2	19	20	NC		
		GND	21	22	NC		

		NC	23	24	NC		
		GND	25	26	GND		
Note 2	/	G17	27	28	R17	/	Note 2
	/	R18	29	30	B17	/	
	/	B18	31	32	G18	/	
	/	G19	33	34	R19	/	
	/	R20	35	36	B19	/	
	/	B20	37	38	G20	/	
		GND	39	40	GND		
Note 2	/	G21	41	42	R21	/	Note 2
	/	R22	43	44	B21	/	
	/	B22	45	46	G22	/	
	/	G23	47	48	R23	/	
	/	R24	49	50	B23	/	
	/	B24	51	52	G24	/	
		GND	53	54	GND		
Note 2	/	G25	55	56	R25	/	Note 2
	/	R26	57	58	B25	/	
	/	B26	59	60	G26	/	
	/	G27	61	62	R27	/	
	/	R28	63	64	B27	/	
	/	B28	65	66	G28	/	
		GND	67	68	GND		
Note 2	/	G29	69	70	R29	/	Note 2
	/	R30	71	72	B29	/	
	/	B30	73	74	G30	/	
	/	G31	75	76	R31	/	
	/	R32	77	78	B31	/	
	/	B32	79	80	G32	/	
		GND	81	82	GND		
Note 5	/	RFU4	83	84	RFU3	/	Note 5
	/	RFU6	85	86	RFU5	/	
	/	RFU8	87	88	RFU7	/	
	/	RFU10	89	90	RFU9	/	
	/	RFU12	91	92	RFU11	/	
	/	RFU14	93	94	RFU13	/	
		GND	95	96	GND		
Note 5	/	RFU16	97	98	RFU15	/	Note 5
	/	RFU18	99	100	RFU17	/	
		NC	101	102	NC		
		NC	103	104	NC		
		NC	105	106	NC		
		NC	107	108	NC		
		GND	109	110	GND		
		GND	111	112	GND		
		NC	113	114	NC		
Note 1		VCC	115	116	VCC		Note 1
		VCC	117	118	VCC		
		VCC	119	120	VCC		

JH2							
	Shield grounding	Eth_Shield	1	2	Eth_Shield	Shield grounding	
	Shield grounding	Eth_Shield	3	4	Eth_Shield	Shield grounding	
		NC	5	6	NC		
		NC	7	8	NC		
Gigabit Ethernet port	/	Port1_T0+	9	10	Port2_T0+	/	Gigabit Ethernet port
	/	Port1_T0-	11	12	Port2_T0-	/	
		NC	13	14	NC		
	/	Port1_T1+	15	16	Port2_T1+	/	

	/	Port1_T1-	17	18	Port2_T1-	/	
		NC	19	20	NC		
	/	Port1_T2+	21	22	Port2_T2+	/	
	/	Port1_T2-	23	24	Port2_T2-	/	
		NC	25	26	NC		
	/	Port1_T3+	27	28	Port2_T3+	/	
	/	Port1_T3-	29	30	Port2_T3-	/	
		NC	31	32	NC		
		NC	33	34	NC		
	Test button	TEST_INPUT_KEY	35	36	STA_LED-	Operating indicator	Note 3
		GND	37	38	GND		
	Line coding signal	A	39	40	DCLK	Shift clock output in the first route	
	Line coding signal	B	41	42	DCLK_2	Shift clock output in the second route	
	Line coding signal	C	43	44	LAT	Locking of the signal output	
	Line coding signal	D	45	46	CTRL	Afterglow control signal	
	Line coding signal	E	47	48	OE_RED	Display enabled	
Note 4	Display enabled	OE_BLUE	49	50	OE_GREEN	Display enabled	Note 4
		GND	51	52	GND		
Note 2	/	G1	53	54	R1	/	Note 2
	/	R2	55	56	B1	/	
	/	B2	57	58	G2	/	
	/	G3	59	60	R3	/	
	/	R4	61	62	B3	/	
	/	B4	63	64	G4	/	
		GND	65	66	GND		
Note 2	/	G5	67	68	R5	/	Note 2
	/	R6	69	70	B5	/	
	/	B6	71	72	G6	/	
	/	G7	73	74	R7	/	
	/	R8	75	76	B7	/	
	/	B8	77	78	G8	/	
		GND	79	80	GND		
Note 2	/	G9	81	82	R9	/	Note 2
	/	R10	83	84	B9	/	
	/	B10	85	86	G10	/	
	/	G11	87	88	R11	/	
	/	R12	89	90	B11	/	
	/	B12	91	92	G12	/	
		GND	93	94	GND		
Note 2	/	G13	95	96	R13	/	Note 2
	/	R14	97	98	B13	/	
	/	B14	99	100	G14	/	
	/	G15	101	102	R15	/	
	/	R16	103	104	B15	/	
	/	B16	105	106	G16	/	
		GND	107	108	GND		
		NC	109	110	NC		
		NC	111	112	NC		
		NC	113	114	NC		
		NC	115	116	NC		
		GND	117	118	GND		

		GND	119	120	GND		
--	--	-----	-----	-----	-----	--	--

- Note 1. Voltage ranging from 3.3V to 5.5V is recommended for input power (VCC).
- Note 2. RGB data groups must be used in group.
- Note 3. Operating indicator that meets low level is valid.
- Note 4. OE_RED, OE_GREEN and OE_BLUE are display enabled pins. In case that OE_RGB are not controlled separately, OE_RED signal is applied. When PWM chip is used, GCLK signal is enabled.
- Note 5. RFU1–18 are the reserved extended function interfaces. Please refer to “4.4.3 Reference Design for Expandable Interfaces”.

4.4.2 64-Group Serial Data Interface

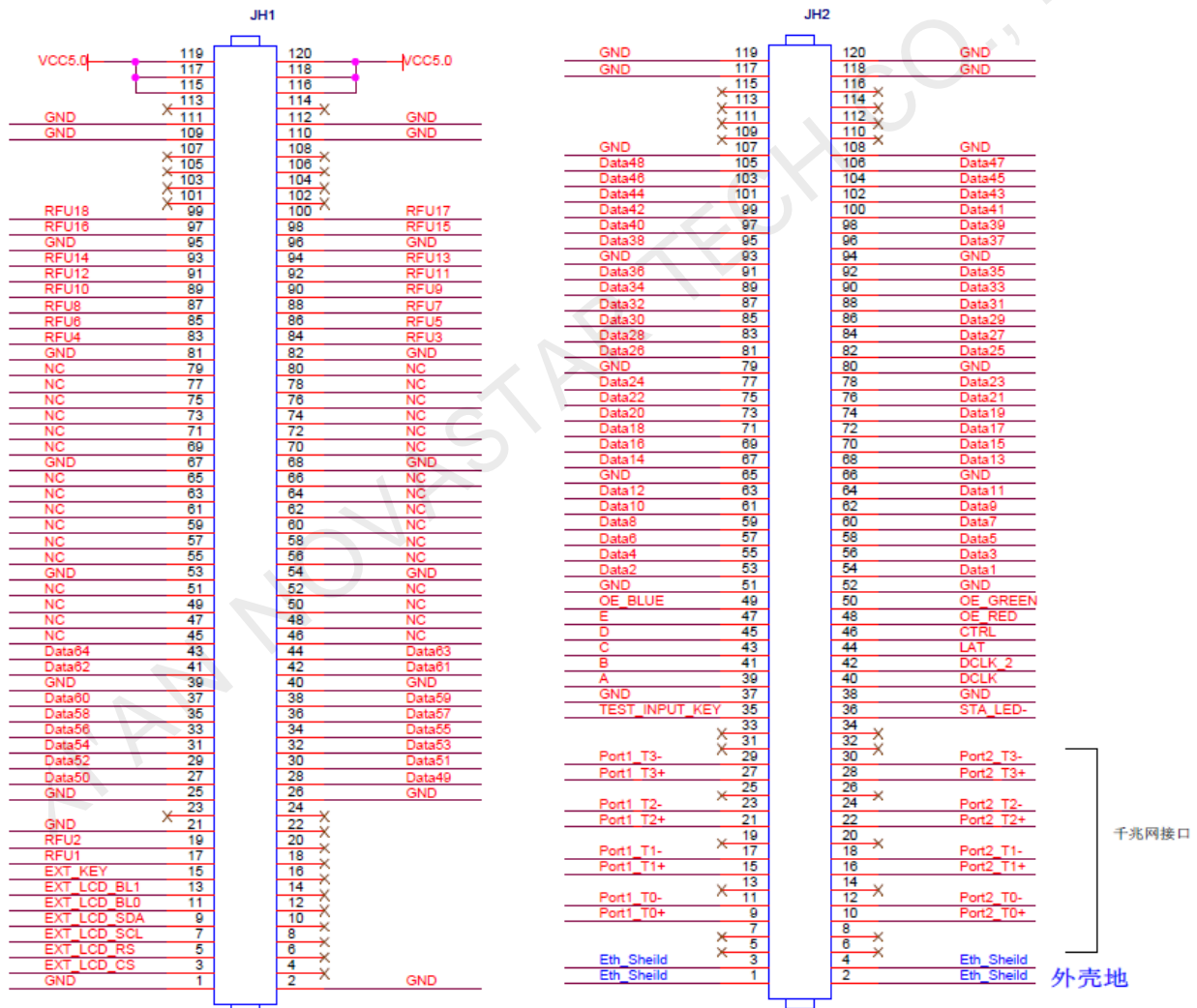

JH1						
		GND	1	2	GND	
LCD	CS signal of LCD	EXT_LCD_CS	3	4	NC	
	RS signal of LCD	EXT_LCD_RS	5	6	NC	

	Clock signal of LCD	EXT_LCD_SCL	7	8	NC		
	Data signal of LCD	EXT_LCD_SDA	9	10	NC		
	Backlight signal 1 of LCD	EXT_LCD_BL0	11	12	NC		
	Backlight signal 2 of LCD	EXT_LCD_BL1	13	14	NC		
	LCD control button	EXT_KEY	15	16	NC		
Note 9	/	RFU1	17	18	NC		
	/	RFU2	19	20	NC		
		GND	21	22	NC		
		NC	23	24	NC		
		GND	25	26	GND		
		Data50	27	28	Data49		
		Data52	29	30	Data51		
		Data54	31	32	Data53		
		Data56	33	34	Data55		
		Data58	35	36	Data57		
		Data60	37	38	Data59		
		GND	39	40	GND		
		Data62	41	42	Data61		
		Data64	43	44	Data63		
		NC	45	46	NC		
		NC	47	48	NC		
		NC	49	50	NC		
		NC	51	52	NC		
		GND	53	54	GND		
		NC	55	56	NC		
		NC	57	58	NC		
		NC	59	60	NC		
		NC	61	62	NC		
		NC	63	64	NC		
		NC	65	66	NC		
		GND	67	68	GND		
		NC	69	70	NC		
		NC	71	72	NC		
		NC	73	74	NC		
		NC	75	76	NC		
		NC	77	78	NC		
		NC	79	80	NC		
		GND	81	82	GND		
Note 9	/	RFU4	83	84	RFU3	/	Note 9
	/	RFU6	85	86	RFU5	/	
	/	RFU8	87	88	RFU7	/	
	/	RFU10	89	90	RFU9	/	
	/	RFU12	91	92	RFU11	/	
	/	RFU14	93	94	RFU13	/	
		GND	95	96	GND		
Note 9	/	RFU16	97	98	RFU15	/	Note 9
	/	RFU18	99	100	RFU17	/	
		NC	101	102	NC		
		NC	103	104	NC		
		NC	105	106	NC		
		NC	107	108	NC		
		GND	109	110	GND		
		GND	111	112	GND		
		NC	113	114	NC		
Note 6		VCC	115	116	VCC		Note 6

		VCC	117	118	VCC	
		VCC	119	120	VCC	

JH2						
Gigabit Ethernet port	Shield grounding	Eth_Shield	1	2	Eth_Shield	Shield grounding
	Shield grounding	Eth_Shield	3	4	Eth_Shield	Shield grounding
		NC	5	6	NC	
		NC	7	8	NC	
	/	Port1_T0+	9	10	Port2_T0+	/
	/	Port1_T0-	11	12	Port2_T0-	/
		NC	13	14	NC	
	/	Port1_T1+	15	16	Port2_T1+	/
	/	Port1_T1-	17	18	Port2_T1-	/
		NC	19	20	NC	
	/	Port1_T2+	21	22	Port2_T2+	/
	/	Port1_T2-	23	24	Port2_T2-	/
		NC	25	26	NC	
	/	Port1_T3+	27	28	Port2_T3+	/
/	Port1_T3-	29	30	Port2_T3-	/	
	NC	31	32	NC		
	NC	33	34	NC		
	Test button	TEST_INPUT_KEY	35	36	STA_LED-	Operating indicator Note 7
		GND	37	38	GND	
	Line coding signal	A	39	40	DCLK	Shift clock output in the first route
	Line coding signal	B	41	42	DCLK_2	Shift clock output in the second route
	Line coding signal	C	43	44	LAT	Locking of the signal output
	Line coding signal	D	45	46	CTRL	Afterglow control signal
	Line coding signal	E	47	48	OE_RED	Display enabled
Note 8	Display enabled	OE_BLUE	49	50	OE_GREEN	Display enabled Note 8
		GND	51	52	GND	
		Data2	53	54	Data1	
		Data4	55	56	Data3	
		Data6	57	58	Data5	
		Data8	59	60	Data7	
		Data10	61	62	Data9	
		Data12	63	64	Data11	
		GND	65	66	GND	
		Data14	67	68	Data13	
		Data16	69	70	Data15	
		Data18	71	72	Data17	
		Data20	73	74	Data19	
		Data22	75	76	Data21	
		Data24	77	78	Data23	
		GND	79	80	GND	
		Data26	81	82	Data25	
		Data28	83	84	Data27	
		Data30	85	86	Data29	
		Data32	87	88	Data31	
		Data34	89	90	Data33	
		Data36	91	92	Data35	
		GND	93	94	GND	

		Data38	95	96	Data37		
		Data40	97	98	Data39		
		Data42	99	100	Data41		
		Data44	101	102	Data43		
		Data46	103	104	Data45		
		Data48	105	106	Data47		
		GND	107	108	GND		
		NC	109	110	NC		
		NC	111	112	NC		
		NC	113	114	NC		
		NC	115	116	NC		
		GND	117	118	GND		
		GND	119	120	GND		

Note 6. Voltage ranging from 3.3V to 5.5V is recommended for input power (VCC).

Note 7. Operating indicator that meets low level is valid.

Note 8. OE_RED, OE_GREEN and OE_BLUE are display enabled pins. In case that OE_RGB are not controlled separately, OE_RED is applied. While PWM chip is used, GCLK signal is enabled.

Note 9. RFU1–18 are the reserved extended function interfaces. Please refer to “[4.4.3 Reference Design for Expandable Interfaces](#)”.

4.4.3 Reference Design for Expandable Interfaces

Expandable Interfaces			
Expandable Interface	Recommended Smart Module Interface	Recommended Module Flash Interface	Description
RFU1	Reserved	Reserved	Reserved pin that connects to MCU
RFU2	Reserved	Reserved	Reserved pin that connects to MCU
RFU3	HUB_CODE0	HUB_CODE0	Flash control interface 1
RFU4	HUB_SPI_CLK	HUB_SPI_CLK	Clock signal of the serial interface
RFU5	HUB_CODE1	HUB_CODE1	Flash control interface 2
RFU6	HUB_SPI_CS	HUB_SPI_CS	CS signal of the serial interface
RFU7	HUB_CODE2	HUB_CODE2	Flash control interface 3
RFU8	/	HUB_SPI_MOSI	Module Flash storage data input
	HUB_UART_TX	/	TX signal of the smart module
RFU9	HUB_CODE3	HUB_CODE3	Flash control interface 4
RFU10	/	HUB_SPI_MISO	Module Flash storage data output
	HUB_UART_RX	/	RX signal of the smart module
RFU11	HUB_H164_CSD	HUB_H164_CSD	74HC164 data signal
RFU12	/	/	/
RFU13	HUB_H164_CLK	HUB_H164_CLK	74HC164 Clock signal
RFU14	POWER_STA1	POWER_STA1	1Dual-power detection signal 1
RFU15	MS_DATA	MS_DATA	Dual-card backup connection signal
RFU16	POWER_STA2	POWER_STA2	2Dual-power detection signal 2
RFU17	MS_ID	MS_ID	Dual-card backup identification signal
RFU18	HUB_CODE4	HUB_CODE4	Flash control interface 5

Description:

RFU8 and RFU10 are signal multiplexing expandable interfaces for which the interfaces of either **Recommended Smart Module Interface** or **Recommended Module Flash Interface** can be selected at a time.

XI'AN NOVASTAR TECH CO., LTD

5 Software Structure

Program download method:

Visit www.novastar.tech and choose **Download > Firmware**. On the **Firmware** section, choose the desired program package to download.

XI'AN NOVASTAR TECH CO., LTD

6 Typical Networking

A5s is applied to LED display synchronous system which is generally composed of the LED display, HUB board, receiving card, video controller and controller peripheral. The receiving card is connected to the display over a HUB board.

Synchronous system requires connecting a computer to display the computer's images and texts on the LED screen. Structure of the synchronous system is as shown in the following figure.



7 Specifications

Input voltage	DC 3.3 V–5.5 V
Rated current	0.5 A
Rated power consumption	2.5 W
Operating temperature	-20°C–70°C
Storage temperature	-25°C–125°C
Operating humidity	10% RH–90% RH
Dimension	70.0 mm × 45.0 mm × 7.3 mm
Net weight	17.3 g
Certification	<ul style="list-style-type: none">• EMC Class B• RoHS
Packing	The antistatic bag and anti-collision foam are prepared for each receiving card. Dimension of the packing box: 378.0 mm × 190.0 mm × 120.0 mm, each of 40 receiving cards.

A Acronyms and Abbreviations

E

EMC Electromagnetic Compatibility

F

FPGA Field-Programmable Gate Array

L

LED Light Emitting Diode

M

MCU Microcontroller Unit

R

RCFG Receiving Card Configuration

B Terms

Calibration coefficient

Calibration system generates a group of values for each LED lamp, including information about brightness and chroma. After display calibration, the calibration values of each lamp are just the calibration coefficient.

Smart module

The smart module is composed of Flash and MCU.

The Flash could store calibration coefficients and module information. MCU could communicate with the receiving card to realize monitoring over temperature, voltage and wiring communication status, as well as LED error detection.

The smart module could make monitoring unit smaller, requiring no independent monitoring card and saving cabinet space.

Mapping

After the Mapping function is enabled on NovaLCT, the target cabinet will display the cabinet number and Ethernet port information, and the user could get the receiving card's location and wiring route.

Error detection

Perform status detection for each LED lamp. If the LED lamp fails, the user could notify in a timely manner upon monitoring system.