



Specifications

Receiving Card A4

Overview

A4 is Nova's high-end mini receiving card series with small size and full functions. It has adopted DDR3 interface which makes it easy to fit various electrical structures. The board card has integrated network transformer to simplify design for users. One board card can suit all kinds of applications.

A single A4 card is able to load 256*256 pixels. It supports many utility functions such as module Flash management interface, smart module management, dual backup of calibration coefficients, voltage and temperature detection etc. With specific design of circuit and program, A4 is able to effectively reduce the electromagnetic radiation of the system and help users to easily pass the EMC certification.

Features

- 1) Single card supports 256*256 pixels.
- 2) Single card supports parallel output of 24-group RGB signal.
- 3) Single card supports output of 64-group serial data.
- 4) A4 has integrated network transformer to simplify the design for users.
- 5) A4 supports various hot backups such as loop backup, dual card backup, dual power backup etc. and seamless switching.
- 6) A4 supports dual backup of display parameters.
- 7) A4 supports module Flash management and allows for the storage of calibration coefficients and module information.
- 8) A4 supports applying module Flash calibration coefficients through

one-click.

- 9) A4 supports smart module with the functions of storing and managing information like calibration coefficients, module information, module parameters etc. as well as flat cable detection and LED pixel-by-pixel error detection and no need for monitoring card.
- 10) A4 supports LCD Human-Computer Interaction (HCI).
- 11) A4 supports temperature monitoring, supply voltage monitoring, and network cable communication status monitoring.
- 12) A4 supports pixel-by-pixel brightness/chroma calibration.
- 13) A4 supports prestoring picture settings.
- 14) A4 supports configuration file readback.
- 15) A4 supports firmware program backup and readback.
- 16) With specific EMC design to effectively reduce electromagnetic radiation.

Output interface definitions

1) 24-group parallel data mode

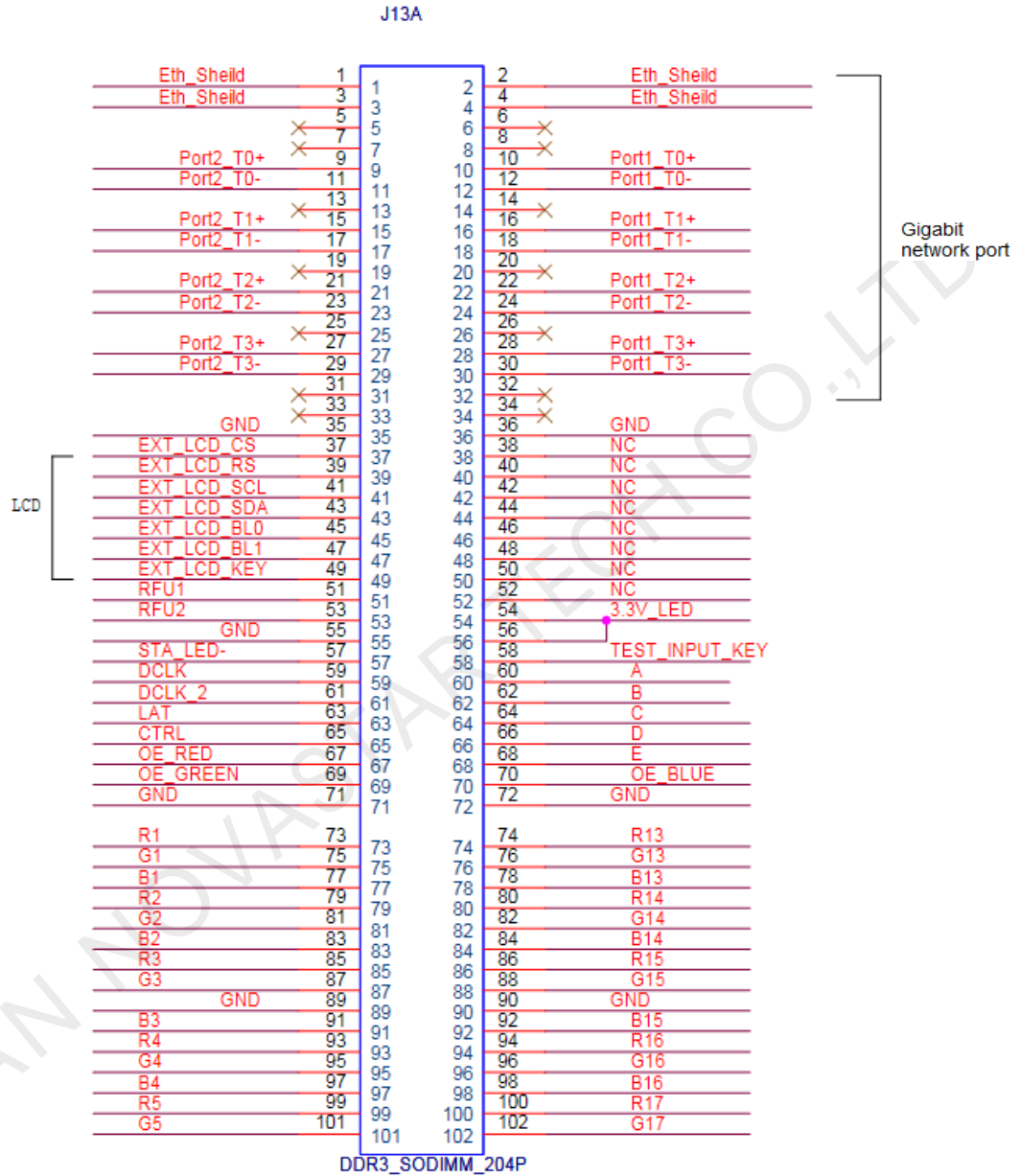

J13B

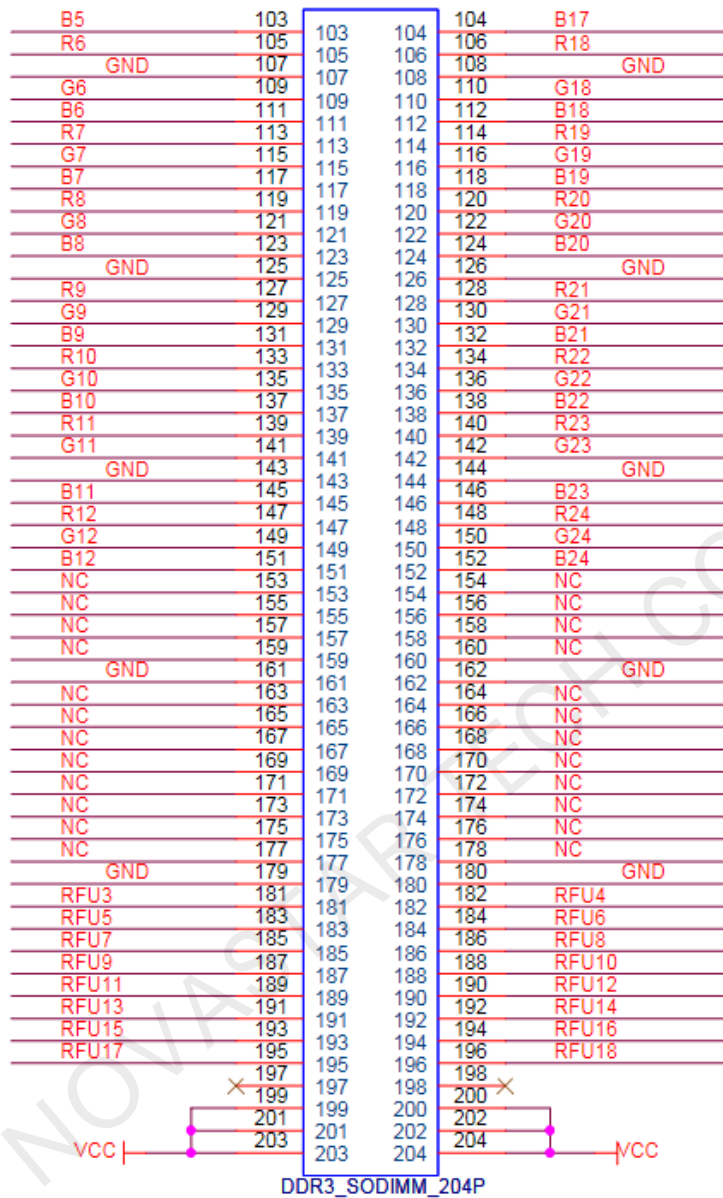

Supporting 24-group parallel data and the definition is shown as below:

Gigabit network port	Case GND	Eth_Sheild	1	2	Eth_Sheild	Case GND	Gigabit network port
	Case GND	Eth_Sheild	3	4	Eth_Sheild	Case GND	
		NC	5	6	NC		
		NC	7	8	NC		
	/	Port2_TRD[0]+	9	10	Port1_TRD[0]+	/	
	/	Port2_TRD[0]-	11	12	Port1_TRD[0]-	/	
		NC	13	14	NC		
	/	Port2_TRD[1]+	15	16	Port1_TRD[1]+	/	
	/	Port2_TRD[1]-	17	18	Port1_TRD[1]-	/	
		NC	19	20	NC		
	/	Port2_TRD[2]+	21	22	Port1_TRD[2]+	/	
	/	Port2_TRD[2]-	23	24	Port1_TRD[2]-	/	
		GND	25	26	GND		
	/	Port2_TRD[3]+	27	28	Port1_TRD[3]+	/	
	/	Port2_TRD[3]-	29	30	Port1_TRD[3]-	/	
	NC	31	32	NC			
	NC	33	34	NC			
	GND	35	36	GND			
LCD	CS signal of LCD	EXT_LCD_CS	37	38	NC		
	RS signal of LCD	EXT_LCD_RS	39	40	NC		
	Clock signal of LCD	EXT_LCD_SCL	41	42	NC		
	Data signal of LCD	EXT_LCD_SDA	43	44	NC		
	Backlight signal 1 of LCD	EXT_LCD_BL0	45	46	NC		
	Backlight signal 2 of LCD	EXT_LCD_BL1	47	48	NC		
	LCD control key	EXT_LCD_KEY	49	50	NC		
See Notes5	/	RFU1	51	52	NC		
	/	RFU2	53	54	3.3V_LED	3.3V Auxiliary Output, see applications in Note 6	
		GND	55	56			
	Operating indicator light	STA_LED-	57	58	TEST_INPUT_KEY	Test key	
	1st way shift clock output	DCLK	59	60	A	Row decoding signal	
	2nd way shift clock output	DCLK_2	61	62	B	Row decoding signal	

	Latch signal output	LAT	63	64	C	Row decoding signal	
	Afterglow control signal	CTRL	65	66	D	Row decoding signal	
See Notes4	Display enable	OE_RED	67	68	E	Row decoding signal	
	Display enable	OE_GREEN	69	70	OE_BLUE	Display enable	See Notes4
		GND	71	72	GND		
	/	R1	73	74	R13	/	
	/	G1	75	76	G13	/	
	/	B1	77	78	B13	/	
	/	R2	79	80	R14	/	
	/	G2	81	82	G14	/	
	/	B2	83	84	B14	/	
	/	R3	85	86	R15	/	
	/	G3	87	88	G15	/	
		GND	89	90	GND		
	/	B3	91	92	B15	/	
	/	R4	93	94	R16	/	
	/	G4	95	96	G16	/	
	/	B4	97	98	B16	/	
	/	R5	99	100	R17	/	
	/	G5	101	102	G17	/	

	/	B5	103	104	B17	/	
	/	R6	105	106	R18	/	
		GND	107	108	GND		
	/	G6	109	110	G18	/	
	/	B6	111	112	B18	/	
	/	R7	113	114	R19	/	
	/	G7	115	116	G19	/	
	/	B7	117	118	B19	/	
	/	R8	119	120	R20	/	
	/	G8	121	122	G20	/	
	/	B8	123	124	B20	/	
		GND	125	126	GND		
	/	R9	127	128	R21	/	

	/	G9	129	130	G21	/	
	/	B9	131	132	B21	/	
	/	R10	133	134	R22	/	
	/	G10	135	136	G22	/	
	/	B10	137	138	B22	/	
	/	R11	139	140	R23	/	
	/	G11	141	142	G23	/	
		GND	143	144	GND		
	/	B11	145	146	B23	/	
	/	R12	147	148	R24	/	
	/	G12	149	150	G24	/	
	/	B12	151	152	B24	/	
		NC	153	154	NC		
		NC	155	156	NC		
		NC	157	158	NC		
		NC	159	160	NC		
		GND	161	162	GND		
		NC	163	164	NC		
		NC	165	166	NC		
		NC	167	168	NC		
		NC	169	170	NC		
		NC	171	172	NC		
		NC	173	174	NC		
		NC	175	176	NC		
		NC	177	178	NC		
		GND	179	180	GND		
See Notes5	/	RFU3	181	182	RFU4	/	See Notes5
	/	RFU5	183	184	RFU6	/	
	/	RFU7	185	186	RFU8	/	
	/	RFU9	187	188	RFU10	/	
	/	RFU11	189	190	RFU12	/	
	/	RFU13	191	192	RFU14	/	
	/	RFU15	193	194	RFU16	/	
	/	RFU17	195	196	RFU18	/	
		NC	197	198	NC		
See Notes1		VCC	199	200	VCC		See Notes1
		VCC	201	202	VCC		
		VCC	203	204	VCC		

2) 64-group serial data mode

J13A

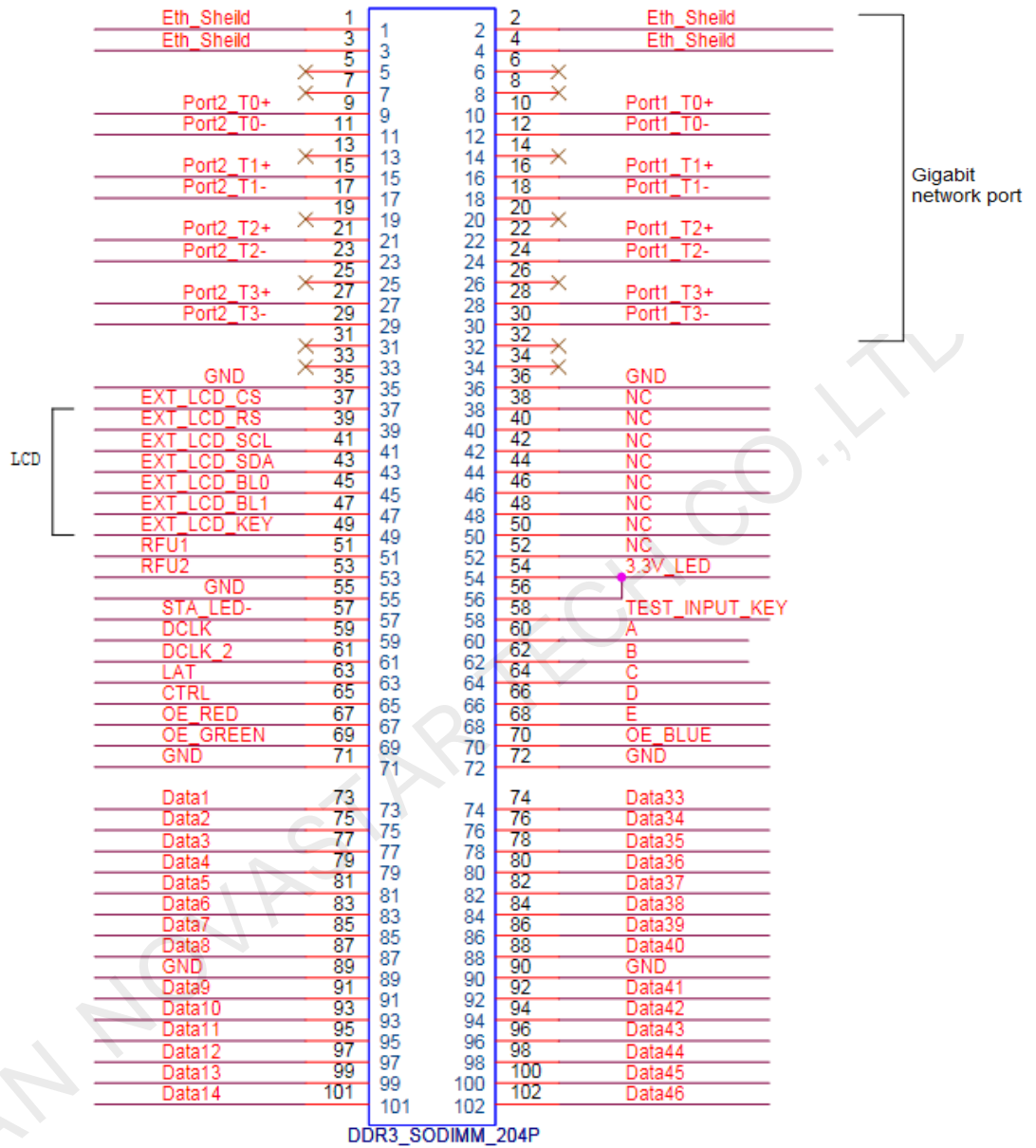

J13B

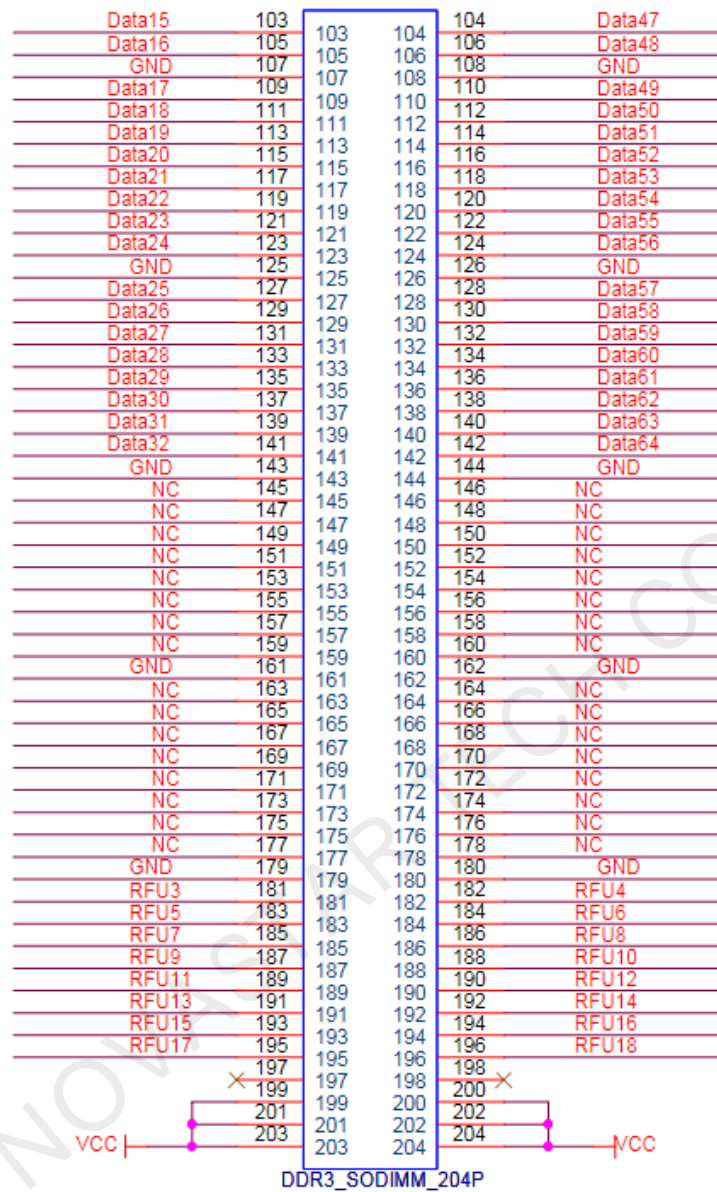

Supporting 64-group serial data and the definition shown as below:

Gigabit network port	Case GND	Eth_Sheild	1	2	Eth_Sheild	Case GND	Gigabit network port
	Case GND	Eth_Sheild	3	4	Eth_Sheild	Case GND	
		NC	5	6	NC		
		NC	7	8	NC		
	/	Port2_TRD[0]+	9	10	Port1_TRD[0]+	/	
	/	Port2_TRD[0]-	11	12	Port1_TRD[0]-	/	
		NC	13	14	NC		
	/	Port2_TRD[1]+	15	16	Port1_TRD[1]+	/	
	/	Port2_TRD[1]-	17	18	Port1_TRD[1]-	/	
		NC	19	20	NC		
	/	Port2_TRD[2]+	21	22	Port1_TRD[2]+	/	
	/	Port2_TRD[2]-	23	24	Port1_TRD[2]-	/	
		GND	25	26	GND		
	/	Port2_TRD[3]+	27	28	Port1_TRD[3]+	/	
/	Port2_TRD[3]-	29	30	Port1_TRD[3]-	/		
	NC	31	32	NC			
	NC	33	34	NC			
	GND	35	36	GND			
LCD	CS signal of LCD	EXT_LCD_CS	37	38	NC		
	RS signal of LCD	EXT_LCD_RS	39	40	NC		
	Clock signal of LCD	EXT_LCD_SCL	41	42	NC		
	Data signal of LCD	EXT_LCD_SDA	43	44	NC		
	Backlight signal 1 of LCD	EXT_LCD_BL0	45	46	NC		
	Backlight signal 2 of LCD	EXT_LCD_BL1	47	48	NC		
	LCD control key	EXT_LCD_KEY	49	50	NC		
See Notes5	/	RFU1	51	52	NC	3.3V Auxiliary Output, see applications in Note 6	
	/	RFU2	53	54	3.3V_LED		
/	GND	55	56				
	Operating indicator light	STA_LED-	57	58	TEST_INPUT_KEY	Test key	
	1st way shift clock output	DCLK	59	60	A	Row decoding	

						signal	
	2nd way shift clock output	DCLK_2	61	62	B	Row decoding signal	
	Latch signal output	LAT	63	64	C	Row decoding signal	
	Afterglow control signal	CTRL	65	66	D	Row decoding signal	
See Notes4	Display enable	OE_RED	67	68	E	Row decoding signal	
	Display enable	OE_GREEN	69	70	OE_BLUE	Display enable	See Notes4
		GND	71	72	GND		
	/	Data1	73	74	Data33	/	
	/	Data2	75	76	Data34	/	
	/	Data3	77	78	Data35	/	
	/	Data4	79	80	Data36	/	
	/	Data5	81	82	Data37	/	
	/	Data6	83	84	Data38	/	
	/	Data7	85	86	Data39	/	
	/	Data8	87	88	Data40	/	
		GND	89	90	GND		
	/	Data9	91	92	Data41	/	
	/	Data10	93	94	Data42	/	
	/	Data11	95	96	Data43	/	
	/	Data12	97	98	Data44	/	
	/	Data13	99	100	Data45	/	
	/	Data14	101	102	Data46	/	

	/	Data15	103	104	Data47	/	
	/	Data16	105	106	Data48	/	
		GND	107	108	GND		
	/	Data17	109	110	Data49	/	
	/	Data18	111	112	Data50	/	
	/	Data19	113	114	Data51	/	

	/	Data20	115	116	Data52	/	
	/	Data21	117	118	Data53	/	
	/	Data22	119	120	Data54	/	
	/	Data23	121	122	Data55	/	
	/	Data24	123	124	Data56	/	
		GND	125	126	GND		
	/	Data25	127	128	Data57	/	
	/	Data26	129	130	Data58	/	
	/	Data27	131	132	Data59	/	
	/	Data28	133	134	Data60	/	
	/	Data29	135	136	Data61	/	
	/	Data30	137	138	Data62	/	
	/	Data31	139	140	Data63	/	
	/	Data32	141	142	Data64	/	
		GND	143	144	GND		
		NC	145	146	NC		
		NC	147	148	NC		
		NC	149	150	NC		
		NC	151	152	NC		
		NC	153	154	NC		
		NC	155	156	NC		
		NC	157	158	NC		
		NC	159	160	NC		
		GND	161	162	GND		
		NC	163	164	NC		
		NC	165	166	NC		
		NC	167	168	NC		
		NC	169	170	NC		
		NC	171	172	NC		
		NC	173	174	NC		
		NC	175	176	NC		
		NC	177	178	NC		
		GND	179	180	GND		
See Notes5	/	RFU3	181	182	RFU4	/	See Notes5
	/	RFU5	183	184	RFU6	/	
	/	RFU7	185	186	RFU8	/	
	/	RFU9	187	188	RFU10	/	
	/	RFU11	189	190	RFU12	/	

	/	RFU13	191	192	RFU14	/	
	/	RFU15	193	194	RFU16	/	
	/	RFU17	195	196	RFU18	/	
		NC	197	198	NC		
See Notes1		VCC	199	200	VCC		See Notes1
		VCC	201	202	VCC		
		VCC	203	204	VCC		

Notes1. It is recommended that input power VCC choose 5.0V.

Notes2. 2 RGB data group must be used in pairs.

Notes3. 3 Operating indicator light is low effective signal.

Notes4. OE_RED, OE_GREEN, OE_BLUE are display enable. Use OE_RED when OE_RGB don't control separately. It is GCLK signal when using PWM chip.

Notes5. RFU1-18 is reserve expansion function interface and see details in the reference designs of other extended functions.

Notes6. It' s only limited to supply power for low current applications like indicator lights, pull-up and so on. High current applications need to use external 3.3V power supply.

Dimensions (Unit: mm)

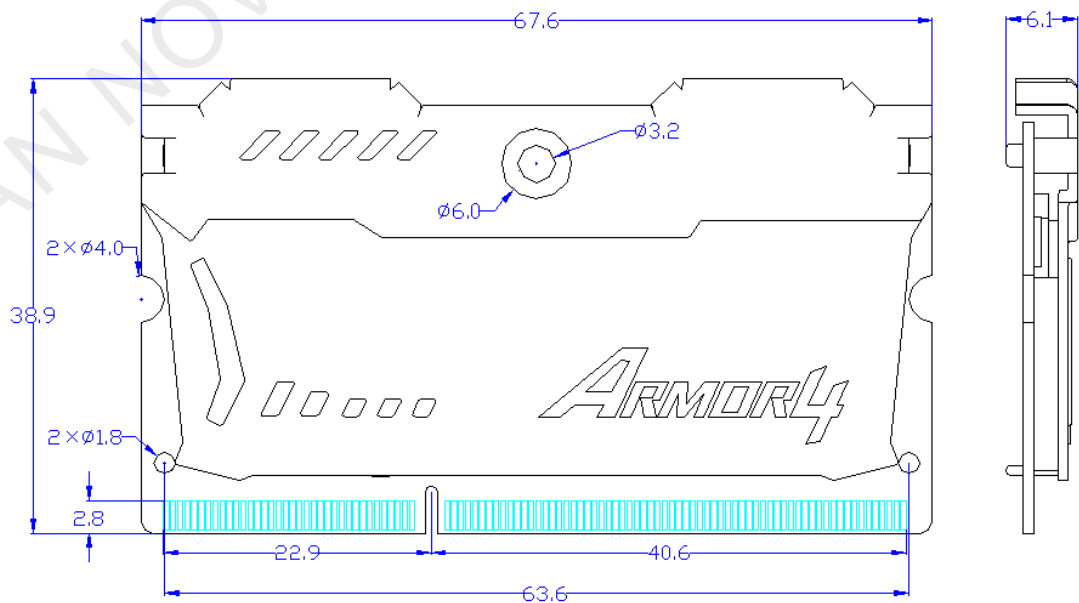
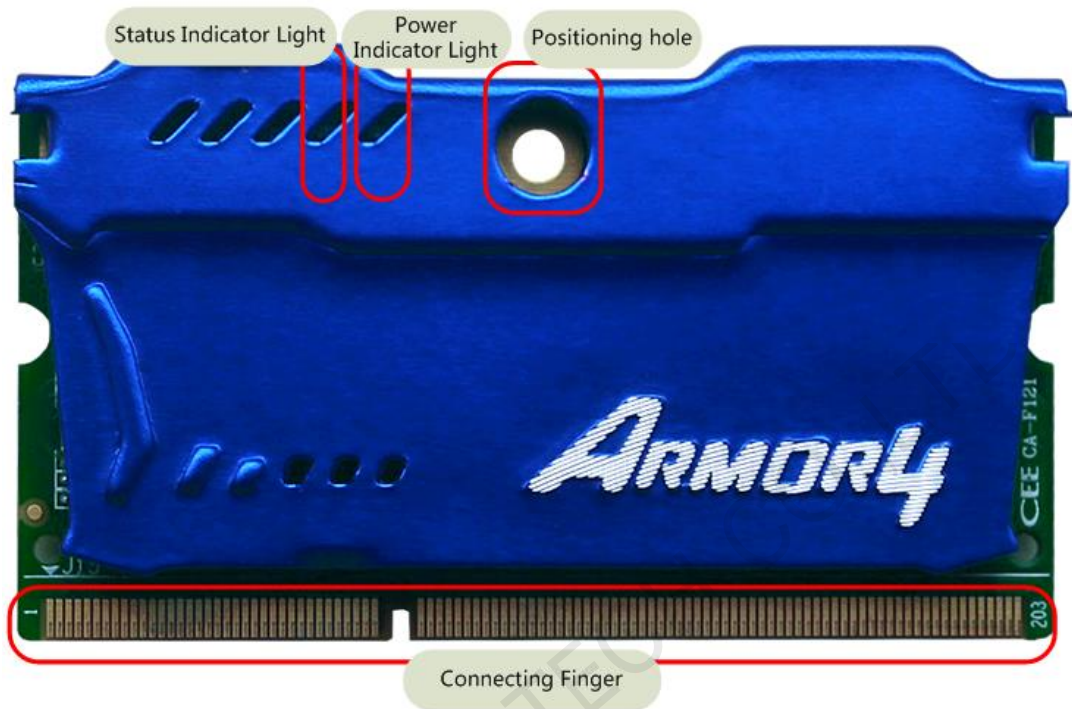

Fig. 1 Front face dimensions of A4 receiving card

Appearance



Notes1: Positioning hole is connected to GND.

Fig. 2 Front view of A4 receiving card

Specifications

Storage and transportation temperature	-40°C ~ 100°C
Temperature of working environment	-25°C ~ 85°C
Input voltage	DC 3.3V~6V
Rated current	0.4A
Rated power consumption	2.0W
Net Weight	14.6g